

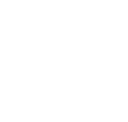

SWP
Water Pumps



Monoblock centrifugal pumps



Approvals



DHM-Pump

- 1- Cast Iron Pump body
- 2- Stainless steel /Brass impeller
- 3- AISI 304 shaft
- 4- Max Liquid temperature: +60°C

Electric Motor

- 1- C & U bearing
- 2- Motor with copper winding
- 3- Built-in thermal protector for single phase motor
- 4- Insulation class : B
- 5- Protection Class: IP44
- 6- Max ambient temperature: +40° C



PUMP TYPE	POWER		INLET/OUTLET	MAX.FLOW	MAX.HEAD	G.W	PACKING DIMENSION	QTY
	Kw	HP						
DHM/5C	0.60	0.8	2"x2"	350	12.5	14.8	350x205x270	1500
DHM/5B	0.75	1.0	2"x2"	350	13.7	15.7	350x205x270	1500
DHM/5BM	1.10	1.5	2"x2"	400	20.2	21.2	415x250x294	950
DHM/5AM	1.50	2.0	2"x2"	400	22.5	22.5	415x250x294	950
DHM/6C	1.10	1.5	3"x3"	750	14	28.6	445x279x355	670
DHM/6CR	1.10	1.5	4"x4"	750	14	30.0	445x279x355	670
DHM/6B	1.50	2.0	3"x3"	850	17.5	29.8	445x279x355	670
DHM/6BR	1.50	2.0	4"x4"	850	17.5	31.0	445x279x355	670
DHM/6A	2.20	3.0	3"x3"	1100	18.5	39.6	518x278x345	600
DHM/6AR	2.20	3.0	4"x4"	1100	18.5	40.5	518x278x345	600
DHM/7B	3.00	4.0	3"x3"	1200	21.8	41.0	518x278x345	600
DHM/7BR	3.00	4.0	4"x4"	1200	21.8	42.0	518x278x345	600
DHM/7AR	4.00	5.5	4"x4"	1850	20	90.0	670x350x490	260

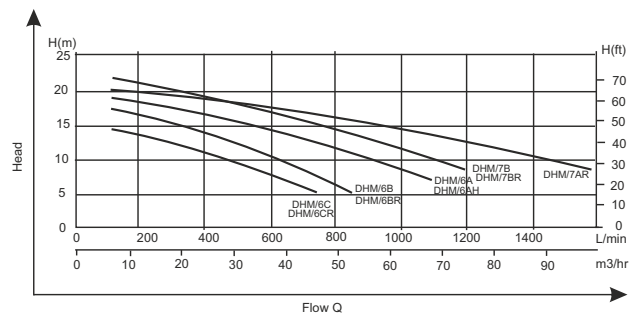
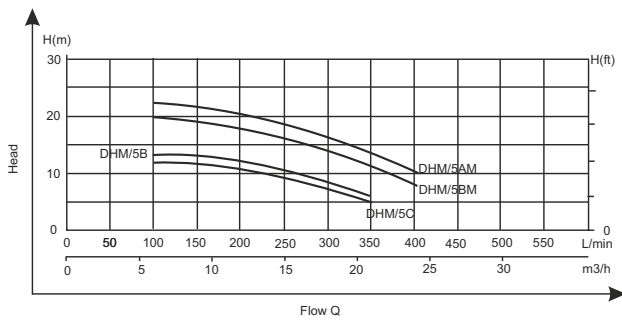

Structure

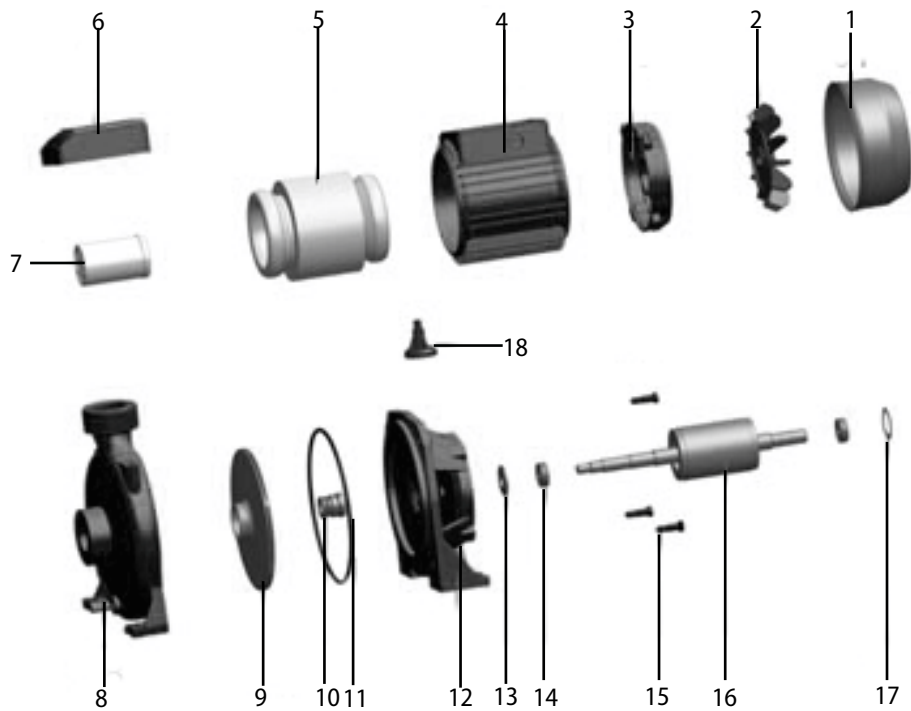

1	Fan Cover	10	Mechanical Seal
2	Fan	11	O Ring
3	Rear end Cover	12	Pump Support
4	Base	13	Thrower
5	Stator	14	Bearing
6	Capacitor Cover	15	Hexagon headed bolt
7	Capacitor	16	Rotor
8	Pump Body	17	Wave Washer
9	Impeller	18	Arm-Brace